

Wasp Major - 22.6-6.5 2020KV

Technical Datas

KV	2020
Configu-ration	12N14P
Stator Diamter	22.6mm
Stator Length	6.5mm
Shaft Diameter	4mm(Hollow)
Motor Dimension(Dia.*Len)	Φ 28.49*30.6mm
Weight(g)	30.5 (3cm Wire)
Idle current(10)@10V(A)	1.2
No.of Cells(Lipo)	5~6S
Max Continuous Power(W) 5S	920
Internal Resistance	49mΩ
Max Current(5S)	38A
Max.Efficiency Current	(3.5-7A)>87%

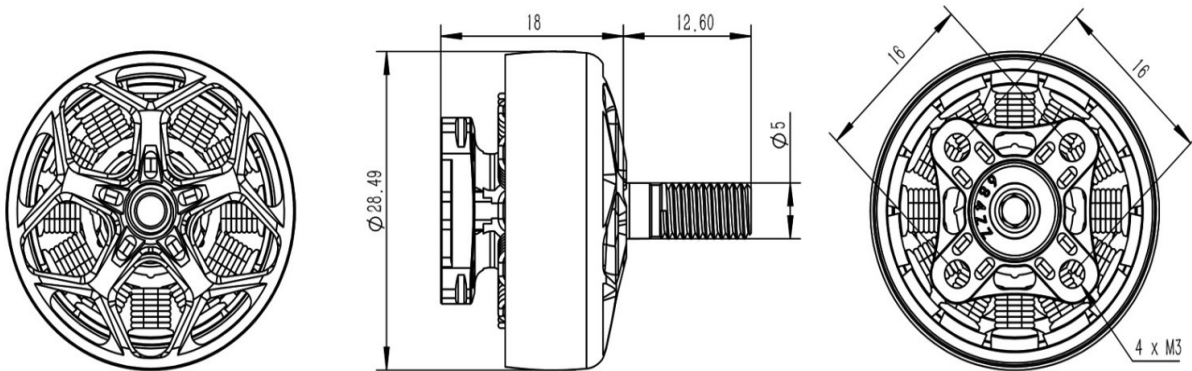

Prop (inch)	Voltages (V)	Throttle (%)	Load Currency (A)	Pull(g)	Power(W)	Efficiency(g/W)	Temperature(in full throttle load 5's)
HQ EthiX S4	21	50%	6.0	642	126.0	5.095	66°C
		100%	26.6	1724	558.6	3.086	
	24	50%	6.7	754	160.8	4.689	76°C
		100%	32.4	2039	777.6	2.622	
HQ EthiX S5	21	50%	6.7	705	140.7	5.011	74°C
		100%	31.2	1852	655.2	2.827	
	24	50%	8.3	853	199.2	4.282	85°C (Hot)
		100%	38.0	2195	912.0	2.407	
DAL T5147.5	21	50%	5.2	604	109.2	5.531	64°C
		100%	25.3	1721	531.3	3.239	
	24	50%	7.1	809	170.4	4.748	75°C
		100%	32.2	2069	772.8	2.677	
GF 5152	21	50%	5.8	677	121.8	5.558	72°C
		100%	30.6	1715	642.6	2.669	
	24	50%	8.6	817	206.4	3.958	84°C
		100%	37.8	2013	907.2	2.219	
GF 6*4.5*2	21	50%	7.4	870	155.4	5.598	79°C
		100%	33.5	2179	703.5	3.097	

■ Airplane

□ Helicopter

■ Vtol