

MOTORS: SmooX1404Plus -3750KV

Technical Datas	
KV	3750
Configu-ration	9N12P
Stator Diamter	12mm
Stator Length	4mm
Shaft Diameter	1.5mm (2mm inside)
Motor Dimension(Dia.*Len)	Φ 19.2*13.1mm
Weight(g)	9 (3cm wire)
Idle current(10)@10V(A)	0.57
No.of Cells(Lipo)	3S-4S
Max Continuous Power(W)3S	150
Internal Resistance	250mΩ
Max Current(3S)	9.6A
Max.Efficiency Current	(2-4A)>82%

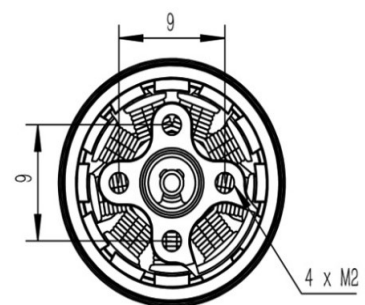
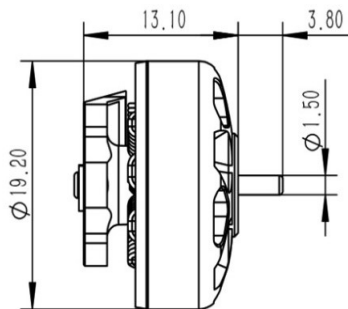
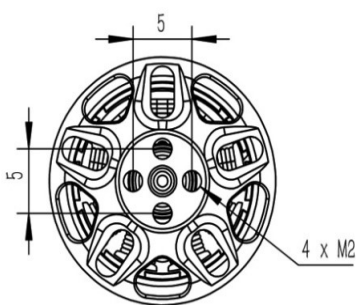

Prop (inch)	Voltages (V)	Throttle (%)	Load Currency (A)	Pull(g)	Power(W)	Efficiency(g/W)	Temperature(in full throttle load 3 Secs)
GF2.5*4*3	11.1	25%	0.55	65	6.1	10.647	51°C
		50%	3.45	191	38.3	4.988	
	14.8	75%	1.15	106	12.8	8.304	61°C
		100%	5.9	302	65.5	4.611	
HQ 3*2.5*3	11.1	50%	1.15	99	12.8	7.756	62°C
		100%	6.3	269	69.9	3.847	
	14.8	50%	1.95	154	28.9	5.336	77°C
		100%	9	385	133.2	2.890	
HQ 3*3*3	11.1	50%	1.35	106	15.0	7.074	64°C
		100%	6.5	279	72.2	3.867	
	14.8	50%	2.3	168	34.0	4.935	80°C(HOT)
		100%	9.6	401	142.1	2.822	
GF4*2*2	11.1	50%	1.65	146	18.3	7.972	67°C
		100%	7.4	353	82.1	4.298	
<input checked="" type="checkbox"/> Airplane			<input type="checkbox"/> Helicopter			<input checked="" type="checkbox"/> Vtol	

RC IN POWER

E-Mail: INFO@RCINPOWER.COM