

MOTORS: SmooX1404Plus -2750KV

Technical Datas	
KV	2750
Configu-ration	9N12P
Stator Diamter	12mm
Stator Length	4mm
Shaft Diameter	1.5mm (2mm inside)
Motor Dimension(Dia.*Len)	Φ 19.2*13.1mm
Weight(g)	9 (3cm wire)
Idle current(10)@10V(A)	0.35
No.of Cells(Lipo)	4S-6S
Max Continuous Power(W)3S	155
Internal Resistance	400mΩ
Max Current(3S)	6.9A
Max.Efficiency Current	(1.5-2A)>82%

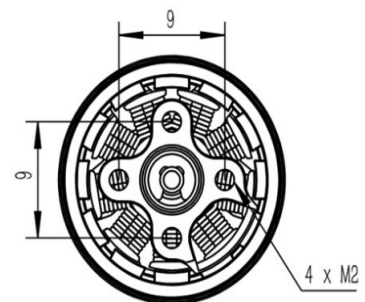
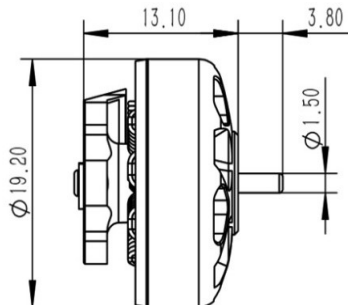
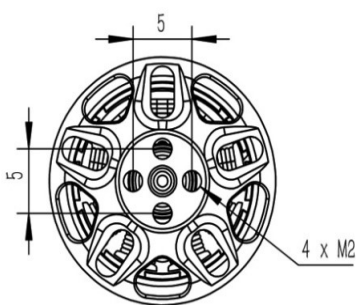

Prop (inch)	Voltages (V)	Throttle (%)	Load Currency (A)	Pull(g)	Power(W)	Efficiency(g/W)	Temperature(in full throttle load 3 Secs)
GF2.5*4*3	14.8	25%	0.2	58	3.0	19.595	50°C
		50%	2.3	178	34.0	5.229	
	22.2	75%	0.8	105	11.8	8.868	60°C
		100%	3.75	300	55.5	5.405	
HQ 3*2.5*3	14.8	50%	0.8	89	11.8	7.517	61°C
		100%	4	259	59.2	4.375	
	22.2	50%	1.2	140	26.6	5.255	76°C
		100%	6.3	389	139.9	2.781	
HQ 3*3*3	14.8	50%	0.75	106	11.1	9.550	63°C
		100%	4.3	279	63.6	4.384	
	22.2	50%	1.45	161	32.2	5.002	79°C
		100%	6.9	405	153.2	2.644	
GF4*2*2	14.8	50%	0.85	128	12.6	10.175	66°C
		100%	5	351	74.0	4.743	
<input checked="" type="checkbox"/> Airplane			<input type="checkbox"/> Helicopter			<input checked="" type="checkbox"/> Vtol	

RC IN POWER

E-Mail: INFO@RCINPOWER.COM